

Installation Instructions

INSTRUCTIONS PERTAINING TO A RISK OF FIRE, OR INJURY TO PERSONS.

IMPORTANT SAFETY INSTRUCTIONS. SAVE THESE INSTRUCTIONS.

(Failure to follow the warnings and instructions on this sheet could result in fire, injury, failure of product, and/or voiding of warranty.)

1. Do not touch while lamp is on. Turn off/unplug and allow to cool before replacing lamp.
2. Lamp gets HOT quickly! Contact only switch/plug when turning on.
3. Keep lamp away from materials that may burn.
4. Do not install fixture with MR16 halogen lamp options in contact with combustible materials.
5. Do not touch lamp at any time. Use a soft cloth. Oil from your skin may damage lamp.
6. Do not operate with damaged or missing parts.
7. Do not disassemble beyond cover & faceplate/cap removal to facilitate lamp and accessory installation/replacement, or as otherwise directed in the installation instructions below.
8. Remove any debris or build-up accumulated on the faceplate or lens periodically. Failure to do so could result in reduction in performance, fixture overheating, or fire.
9. Do not install within 10 feet of a pool, spa, or fountain.
10. Have installed in accordance with all applicable installation codes and standards by a person familiar with the construction, operation, and hazards involved. Consult a qualified electrician to ensure correct branch circuit conductor.
11. Cable buried more than 6" must be suitable for direct burial. Direct burial cable may be ordered from Vision3 Lighting.
12. Lens temperatures can get hot enough, with some lamps, to cause injury when touched.
13. Failure to follow these instructions can cause fire, injury, and/or void warranty.

Notes:

- This fixture should not be mounted in such a way that it is buried or in direct contact with the ground or soil.
- This fixture requires a remote transformer or mount option with integral transformer.
- LED models should only be powered and controlled by compatible transformers and control systems. Contact Vision3 Lighting for approved transformer / controls list. Using non-approved transformers / controls could cause the LED to not operate properly or fail.
- Integral LED options come with a High/Low switch. See 'LED Switching' instructions on next page. Switch will be set to 'High' setting at the factory, unless otherwise specified when ordered.
- Use only Vision3 approved Retrofit MR16 LED options and supplied Heatsink Mount, otherwise LED may overheat and fail.
- LED ratings subject to change without notice. See website or contact V3 for most current info.

Caution! Fixture will be hot if lamp is on. Remove power and allow fixture to cool before performing any adjustments or maintenance.

Unpack:

1. Unpack the fixture from its box.
2. Check through all packaging material to make sure there aren't any items hidden in it before discarding.
3. Loosen the Cover Set Screws (3X) and remove the Cover from the Faceplate / Cap assembly (if shipped assembled).
4. Referring to the sketch at right, along with the packing list and order, check that all components are accounted for. Contact Vision3 lighting immediately if any discrepancies are found. Note: depending on the options and accessories ordered, certain components may not be included.

Inspection:

1. Inspect all parts for shipping damage, such as: broken lenses, broken lamps, cut or nicked cable, damage to the cable connector on the Body, cut O-ring, etc. If any damage is found, do not install fixture. Contact Vision3 lighting so that damaged items can be repaired or replaced.
2. Cover and store all parts in a clean, dry, and safe place until it is time for installation. Note: Plastic bags are handy for keeping parts organized and clean during storage.

Installation:

1. Using the information shown for 'Mounting Dimensions', make the required holes in the mounting surface. For the #10 mount holes, use appropriate threaded inserts for the material being mounted in. Note: When using the MR16 Halogen lamp option, this fixture is not suitable for use in contact with combustible materials or insulation. See specification sheet.

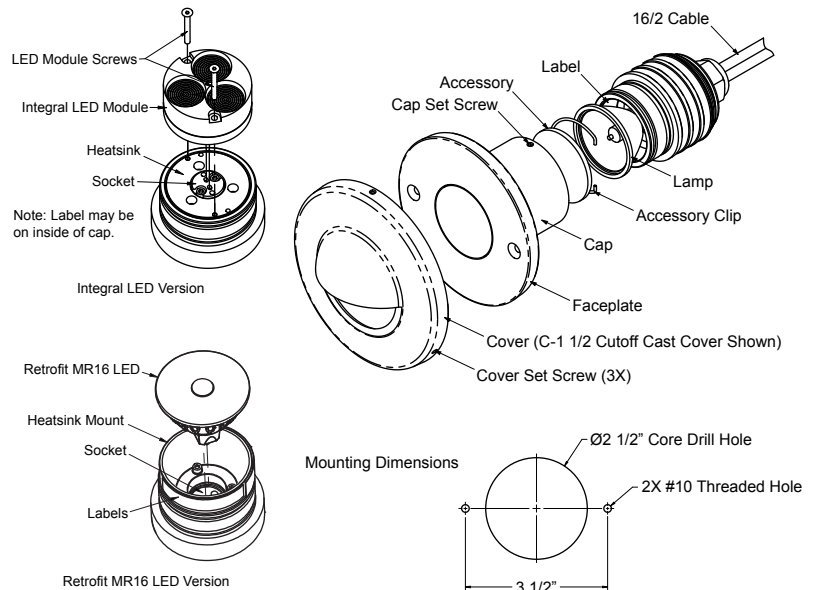

2. Install lamp and accessories, as described below, if not already installed from the factory. Note: Check label for any limitations on Accessories or Lamp wattages.
3. Connect the fixture leads (16/2 Cable) to the power supply wires (not supplied) using the appropriate water tight connectors (not supplied) per applicable codes. It is possible for water to travel thru the strands of the fixtures power leads, so all wiring connections must be done in an industry approved water tight manner. Failure to do so may cause water intrusion related failures. Use enough cable to allow for removal of the fixture from the core drilled hole. Note: Be sure that the power being supplied by the power supply leads matches the rating on the fixture Label.
4. Insert Body in to the core drilled hole until the Faceplate meets wall. Make sure wiring is not kinked or pinched in any way. Note: Silicone sealant can be applied to the back of the Faceplate to prevent water entry into the core drill hole.
5. Thread #10 flat head screws (not supplied) thru the faceplate holes and in to the mount holes to secure the Faceplate to the wall. Note: It is recommended that stainless steel screws be used to prevent corrosion.
6. Loosen the Cover Set Screws (3X) with a 3/32" hex tool (do not remove screws) so that the Cover will slide over the Faceplate.
7. Place the Cover/Cutoff Assembly over the Faceplate and properly orient.

Installation Instructions

INSTRUCTIONS PERTAINING TO A RISK OF FIRE, OR INJURY TO PERSONS.

IMPORTANT SAFETY INSTRUCTIONS. SAVE THESE INSTRUCTIONS.

(Failure to follow the warnings and instructions on this sheet could result in fire, injury, failure of product, and/or voiding of warranty.)

For some options, the Cover and Cutoff will be two separate parts. Make sure the Cutoff fits properly into the recessed groove in the Cover before installing. Note: Cover Assembly should not be installed in an orientation that allows any eyelids or hoods to fill with water or debris.

8. Gently tighten each Cover Set Screw against the side of the Faceplate. Note: Make sure that the Cover/Cutoff Assembly is tightened on to the Faceplate with all three Cover Set Screws; otherwise, it may loosen.

Lamp/LED Module Maintenance:

1. Remove power from fixture and let cool before touching. **Caution! Fixture may still be hot!**
2. Loosen, but do not remove, the Cover Set Screws (3X) and remove the Cover. Note: Thoroughly clean any dirt and debris from the hex in each screw before attempting to loosen. Failure to do so will cause the screw heads to strip.
3. Loosen and remove the screws holding the Faceplate to the wall.
4. Pull the fixture out of the wall, being careful to not twist, kink, or cut any of the wiring.
5. Loosen the Cap Set Screw using a 3/32" hex tool – **do not remove screw!**
6. Remove the Faceplate/Cap Assembly from the Body. Holding the Body and twisting while removing reduces the risk of damaging the O-ring.
7. Inspect O-ring for damage. Replace if necessary.
8. Replace lamp/LED.

For MR16 Halogen Lamp:

- a. Pull lamp straight out. **Caution! Lamp may still be hot! Be sure lamp has cooled before touching.**
- b. Inspect socket for any damage.
- c. Clean inside of fixture and Cap with a clean dry cloth.
- d. Push new lamp straight in, being careful to align pins. **Note:** Replacement lamp must not exceed ratings on Label.

For Integral LED Module:

- a. Loosen and remove the LED Module Screws.
- b. Pull LED straight out. Do not twist or the pins will break off in the socket. **Caution! LED may still be hot! Be sure LED has cooled before touching.**
- c. Clean the grease off of the Heatsink top surface using a rag dipped in alcohol.
- d. Inspect the socket for any damage.
- e. If the replacement LED Module does not come with a thermal transfer pad on the base, apply a thin layer of thermal grease (not supplied) to the surface of the Heatsink that will contact the bottom of the LED Module.
- f. Align the pins on the LED Module with the socket and push straight in. Do not twist or push in at an angle or the pins may be damaged.
- g. Install and tighten the LED Module Screws. **Caution!** Over tightening of screws could crack the LED Module case.

For Retrofit MR16 LED Lamp:

- a. Pull lamp straight out. **Caution! Lamp may still be hot! Be sure lamp has cooled before touching.**
- b. Inspect socket for any damage.
- c. Clean inside of fixture and Cap with a clean dry cloth.
- d. Push new lamp straight in, being careful to align pins. Make sure Retrofit MR16 Lamp fully contacts Heatsink Mount, otherwise lamp may overheat and fail prematurely. **Note:** Replacement lamp must not exceed ratings on Label. Only use Vision3 approved Retrofit MR16 Lamp and supplied Heatsink Mount, otherwise LED may overheat and fail.

9. Install Faceplate/Cap Assembly on to Body by pushing and twisting slowly. If O-ring is excessively dry, use a small amount of Krytox lubricant.
10. Tighten Cap Set Screw with the 3/32" hex tool so that it just bottoms out.

Do not over tighten the Cap Set Screw! This may cause the fixture to not seal properly.

11. Re-install the fixture as described in the Installation section above.

LED Switching (on certain models):

1. Remove the fixture and dis-assemble the Faceplate/Cap and Body assemblies as explained in Lamp Maintenance steps 1 thru 7.
2. Inspect for damage. Replace any damaged parts, if necessary.
3. Clean inside of fixture and Cap with a clean, damp cotton cloth.
4. Find LED High/Low Switch on side of Integral LED Module.
5. Using a pin, small nail, etc, flip the switch in the desired direction. See the LED Module Switch sketch for which direction corresponds to which setting.
6. Re-assemble Faceplate/Cap and Body assemblies, and re-install fixture as explained in Lamp Maintenance steps 9 thru 11.

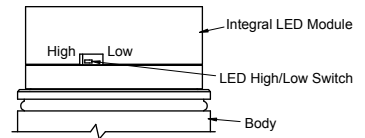

Accessory Maintenance:

1. Remove the fixture and dis-assemble the Faceplate/Cap and Body assemblies as explained in Lamp Maintenance steps 1 thru 7.
2. Remove Accessory Clip from Faceplate/Cap Assembly.
3. Carefully remove Accessories, if any.
4. Inspect Faceplate/Cap, Accessories, and Clip for damage. Replace if necessary.
5. Clean Faceplate/Cap and Accessories with a clean, damp cotton cloth.
6. Carefully install new Accessories into Faceplate/Cap.
7. Compress Clip and push into Faceplate/Cap until it holds Accessories tightly.
8. Re-assemble Faceplate/Cap and Body assemblies, and re-install fixture as explained in Lamp Maintenance steps 9 thru 11.